



→ Slider lift for trucks, trailers and semi-trailers

DH-SO7.20 • 1500 - 2000 kg



In comparison to the standard slider lifts DH-SM(R), the various DH-SO... lifts are equipped with a **double folded platform**: their platform is folded twice and rests on the lift arms when stowed away in travel position. Hence these DH-SO... lifts are specially designed for installation on **commercial vehicles with a too short overhang** to mount standard slider lifts with single folded platform (e.g. semi-trailers with rear steering axle, and centre-axle trailers).

The 2 platform parts are made of light-weight aluminium, to make the unfolding of the platform into work position (and the folding of the platform into travel position) as easy as possible.

The DH-SO.07 offers 1500-2000 kg lift capacity, and serves the top segment of the slider lifts with double folding platforms. It is suitable for trucks from 7 to 25T GVW, for trailers and semi-trailers.

Lift capacity

CAP	CG	LM
1500 kg	750 mm	11.25 kNm
2000 kg	750 mm	15 kNm

Weights [see pg. 15]

ALU / ALU	
1400 mm	485 kg
1600 mm	505 kg
1800 mm	530 kg

Double folded platform for vehicles with short overhang

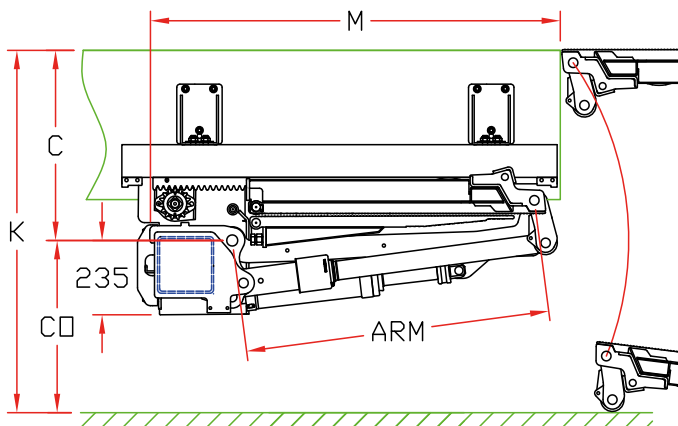

Fitting dimensions

ARM	780	880	980	1080
K max.	1290	1440	1560	1760
C max.	640	710	780	880
CO max.	650	730	780	880
M	1125	1225	1325	1425
V max.	1400	1600	1800	1800
V min.	1400	1400	1600	1800

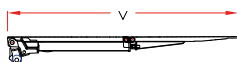

Technical specifications

Lift frame	180 x 180 mm
Cylinders	2 lift cylinders + 2 tilt cylinders
Retraction IN / OUT	Hydromotor + gear wheel system
Type of ride [see pg. 8-9]	Wedged platform. Level ride + automatic tilt at ground level
Platform material	Alu / Alu
Standard platform depths	1400 - 1600 - 1800 mm
Standard platform widths	2300 - 2400 mm Other widths on request (OAP603)
Lift arm lengths	780 - 880 - 980 - 1080 mm
Lift arm widths	800 - 1450 - 1550 mm
Standard control unit [see pg. 11]	OAE030.BT
Standard finish of the lift frame	Hot-dip zinc plated finish [OAT104]