



→ Passenger lift for Multi Passenger Vehicles, minibuses and ambulances

## DH-PH2.03 • 350 kg



The DH-PH2 belongs to a new generation (2010-...) of **fully automatic linear passenger lifts**. It is suitable for mounting inside the rear doors of a wide range of Multi Passenger Vehicles, minibuses and ambulance vehicles.

In comparison to the 1-arm model, the reinforced construction with 2 lift arms provides maximum platform stability. It increases the safety and sense of safety of the platform occupants.

The OWU003 with **horizontally folding platform** can be mounted in smaller vehicles and offers an improved rear view to the driver and passengers. The OWU001 / 002 with **vertical split platform** offer excellent rearward vision and an easy access to the vehicle interior.

Standard

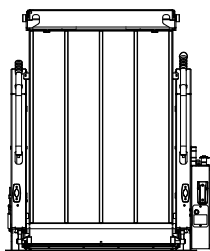

Option OWU001 / OWU002

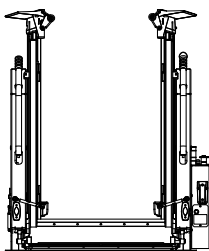

Option OWU003

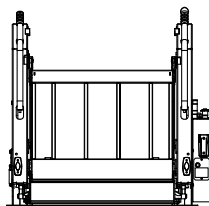

# Safe, reliable and comfortable lift with 2 lift arms

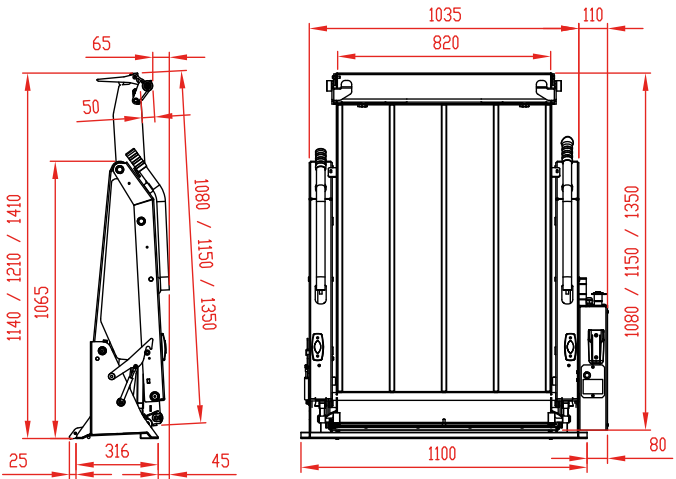

## Lift capacity

| CAP    |
|--------|
| 350 kg |

## Weights [see pg. 15]

| Meshed steel 350 kg |        |
|---------------------|--------|
| 1350 x 820          | 138 kg |
| 1150 x 820          | 134 kg |
| 1080 x 820          | 132 kg |
| OWU001              | +10 kg |
| OWU003              | +6 kg  |

## Fitting dimensions

| ARM    | 700 |
|--------|-----|
| K max. | 900 |

## Technical specifications

|   |   |
|---|---|
| Lift frame  | 2 lift arms   |
| Cylinders   | 2 lift cylinders  |
| Type of ride <small>[see pg. 8-9]</small>         | Flat platform, level ride   |
| Platform details                                  | <ul style="list-style-type: none"> <li>Reinforced platform in meshed steel</li> <li>Automatic roll-stop at the rear edge of the platform</li> <li>Automatic bridge plate and toe-guard at the front edge of the platform</li> </ul> |
| Safety rails                                      | 2, left & right, folding automatically  |
| Standard platform depths                          | 1080 - 1150 - 1350 mm<br>Other depths on request (OWP002.L)   |
| Standard platform widths                          | 820 standard / 920 optional (OWP002.W)  |
| Standard control unit <small>[see pg. 10]</small> | OAE001  |
| Standard finish of the lift frame                 | Protection PLUS [OAT102]  |