



→ Slider lift for light and medium size trucks

DH-SM.15 • 1000 - 1500 kg



The DH-SM.15 is the **lightest of the conventional slider lifts** with single fold platforms. It is equipped with a compact lift frame and short lift arms, in order to **minimize the required overhang**. As a consequence, it forms a modern and lighter weight alternative to the short overhang lift DH-SMP.20 in 1500 kg execution.

In its travel position, the DH-SM.15 is **safely stored underneath the chassis of the vehicle**. It is ideal for operations needing frequent fork lift loading or access to loading docks, and all applications requiring quick and free access to the cargo space.

Lift capacity

CAP	CG	LM
1000 kg	750 mm	7.5 kNm
1500 kg	750 mm	11.25 kNm

Weights [see pg. 15]

STEEL / ALU		ALU / ALU	
1500 mm	420 kg	1500 mm	380 kg
1700 mm	430 kg	1700 mm	390 kg
1800 mm	435 kg	1800 mm	395 kg

Light 4-cylinder slider lift with single fold platform

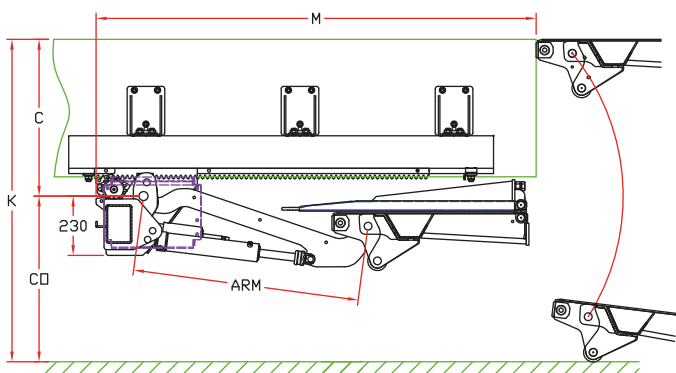

Fitting dimensions

ARM		720	800	880
K max.		1190	1295	1420
C max.		605	665	720
CO max.		585	630	700
M	1500 mm platform	1530	1610	1690
M	1700 mm platform	1630	1710	1790
M	+ option OAP610	-100	-100	-100

Technical specifications

Lift frame	100 x 150 mm
Cylinders	2 lift cylinders + 2 tilt cylinders
Retraction IN / OUT	Hydromotor + gear wheel system
Type of ride [see pg. 8-9]	Wedged platform. Level ride + automatic tilt at ground level
Platform material	Steel / Alu or Alu /Alu
Standard platform depths	1500 - 1700 - 1800 mm
Standard platform widths	2100 - 2300 - 2400 mm Other widths on request (OAP603)
Lift arm lengths	720 - 800 - 880 mm
Lift arm widths	1300 mm
Standard control unit [see pg. 11]	OAE030.BT
Standard finish of the lift frame	Hot-dip zinc plated finish [OAT104]