



→ Cantilever lift for trucks, trailers and semi-trailers

DH-LSU.90 • 7500 - 9000 kg



The heavy duty lift DH-LSU.90 is designed for **extreme lift capacities from 7,500 to 9,000 kg** and is mainly used for the transport of heavy machinery, forklifts, agricultural tractors etc...

The steel platform can be extended to form the rear closure of the vehicle body and can be modified so that it can be inclined in ramp position (option OAH027).

Hydraulic stabilising legs are standard on the DH-LSU.90. It is important to have the chassis sufficiently reinforced for the mounting of this type of tail lift.

Lift capacity

CAP	CG	LM
7500 kg	1000 mm	75 kNm
9000 kg	1000 mm	90 kNm

Weights [see pg. 15]

STEEL platform	
2000 mm	1500 kg
Weights incl. CE bumper	

The absolute top: extreme lift capacities up to 9T

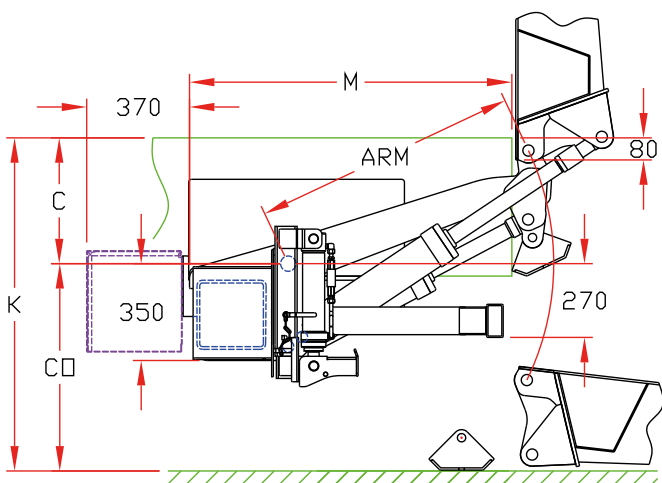

Fitting dimensions

ARM		960
K max.		1460
C max.		625
C min.		200
CO max.		835
M	at C max.	1065 (+370) (*)
M	at C min.	1260 (+370) (*)

(*) incl. power pack fitted centrally at the front of the lift frame

Technical specifications

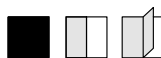

Lift frame	250 x 250 mm
Cylinders	2 lift cylinders + 2 tilt cylinders
Type of ride [see pg. 8-9]	Wedged platform. Level ride + automatic tilt at ground level
Platform material	Reinforced steel platform
Platform overlap under floor	-80 mm (straight platform edge OAP311)
Standard platform depths	Steel: 2000 mm (max. 4500)
Standard platform widths	Steel: 2350 - 2480 - 2500 - 2520 - 2550 mm
Lift arm lengths	960 mm
Lift arm widths	1200 - 1400 - 1600 mm
Standard control unit [see pg. 11]	OAE030.BT
Standard finish of the lift frame	Protection PLUS [OAT102]